

SOLAR Pzs

Deep Cycle PzS Series

GENERAL INFORMATION



UNIBAT Solar PzS are vented - low maintenance 2V cells and designed to meet the needs of the most demanding customers in solar and wind systems. They comply with DIN/EN 60254, IEC 61427 and IEC 60896-11 standards.

Solar PzS batteries are composed of top-quality DIN manufacturing pure raw materials, which offer superior results and reliability thanks to their robust construction based on tubular high pressure (PzS) technology.

Positive tubular plate construction incorporates low antimony lead alloy spines in complete contact with the active material, which is retained by an outer gauntlet. This enables the electrolyte to penetrate freely, ensuring a high power output per unit volume

Negative plates have a grid configuration with pasted highly porous low – antimony lead oxide and the separator is of sleeve - microporous type. Fully enclosed plates cannot develop “mossing” or shorts between the plates.

The density of the electrolyte at 20°C is 1.28 ± 0.01 kg/l. The weight tolerance is $\pm 5\%$.

The lid is hermetically heat-sealed to the container ensuring an excellent bond. This is vital to Mechanical strength, safety, shock resistance and extreme temperatures, making them ideal for stationary applications.

Terminals are specifically designed to ensure that cells are completely watertight, in addition they are connected to build 6, 12, 24 or 48V battery banks through insulated flexible cables.

Screwed M10 connections facilitate assembly and replacement of the elements.

UNIBAT Solar PzS 2V cells are equipped with caps with a tilting lock, which facilitates the escape of gases produced during charging and protects the battery from unwanted spills. In addition, the covers allow the installation of temperature measurement probes.



UNIBAT Solar PzS batteries are optionally equipped with the BFS automatic water filling system, which makes it possible to fill all elements simultaneously. In addition, the BFS plugs facilitate the measurement of the electrolyte density and ensure that the level is correct for the optimal filling of the cells.

UNIBAT Solar PzS batteries are designed for a long service life in cyclic applications, up to 2500 cycles for 50% Depth Of Discharge, or up to 1500 cycles for 80% D.O.D.

Deep Cycle PzS Series

DESIGN FEATURES & BENEFITS

- DIN Tubular Pzs 2V cells for Renewable Energy Systems.
- Low Maintenance and Extended Watering Intervals.
- High capacity tubular constructed design for high cycle applications
- Optimized surface area to allow higher voltages in cold storage applications and greater acid circulation.
- High pressure die cast positive splines corrosion resistant which improves battery life.
- Computer designed negative plate provides more efficient current flow to increase performance.
- Uniform distribution of active material and weight is achieved through a wet filling process which enhances plate uniformity.
- Flip top vent caps for easy filling.
- Over 3" of watering space reduces watering intervals (most other standard tubular and flat plates have between 1" and 2").
- Round tubular gauntlets provide superior resistance to active material shedding.
- Fully enveloped separators reduce the chance of short circuiting.
- Rubber terminal bushings absorb impact and shock.
- Completely insulated copper acid-resistant bolt-on cell connectors and cables prevent short circuiting, have far less voltage leakage and allow for field replacement of cells and cables.

RANGE SUMMARY

Cell Type	Capacity (Ah)			Dimensions (mm)				Weight (kg)	Max. (A) Discharge Current (5s)	Cycles @ 50% D.O.D
	C20	C100	C120	L	W	H1	H2			
SOLAR PzS 315	288	315	336	65	198	405	435	14,2	1.920	2.500
SOLAR PzS 420	384	420	448	83	198	405	435	18,4	2.560	
SOLAR PzS 520	480	520	560	101	198	405	435	22,6	3.200	
SOLAR PzS 625	576	625	672	119	198	405	435	26,7	3.840	
SOLAR PzS 810	744	810	868	83	198	710	740	34,6	4.960	
SOLAR PzS 975	900	975	1050	119	198	565	595	40,3	6.000	
SOLAR PzS 1140	1050	1140	1225	137	198	565	595	50,4	7.000	
SOLAR PzS 1210	1116	1210	1302	119	198	710	740	50,5	7.440	
SOLAR PzS 1300	1200	1300	1400	155	198	565	595	53,1	8.000	

Headquarters: Scholiou 6, Ionia 570 08

Warehouse: C Phase, Industrial Zone Thessaloniki-Sindos

Office: Pefkon 147 & Elaion, Neo Irakleio 141 22

Retail Shop: I.Dragoumi 40, Ionia 570 08

T.: 0030 2310 785722

T.: 0030 2310 570203

T.: 0030 210 2819001

T.: 0030 2310 788506

F.: 0030 2310 760882

F.: 0030 2310 788507

E.: info@unibat-sa.gr

E.: info@unibat.gr

W.: www.unibat-sa.gr

W.: www.unibat.gr

SOLAR Pzs

Deep Cycle PzS Series

CHARGING INSTRUCTIONS

The normal method of solar charging is to charge at the current available from the solar array up to a maximum of 30% C100 Amps until the battery voltage reaches 2.40/2.45Vpc. This period is referred to as the 'bulk charge'.

The regulator then controls the charge voltage at 2.40/2.45Vpc for a set period of 2 to 4 hours. This is termed 'absorption time'.

The charge then reverts to the 'float charge' at 2.27Vpc. In order to avoid electrolyte stratification during this stage, it is strongly recommended to apply an equalization charge every 20 days. This mixes the electrolyte and brings weaker cells into line with those that are stronger.

PERFORMANCE CURVES

DISCHARGING CURVES

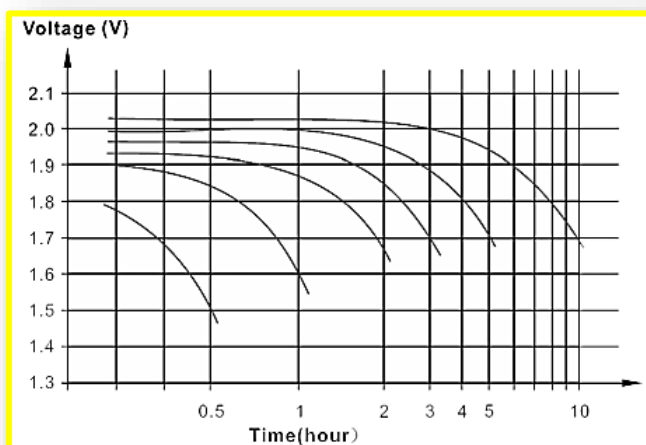

CYCLES vs D.O.D

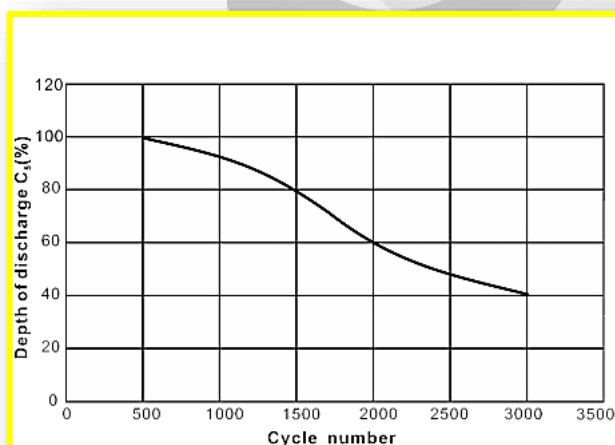

ELECTROLYTE DENSITY vs CAPACITY

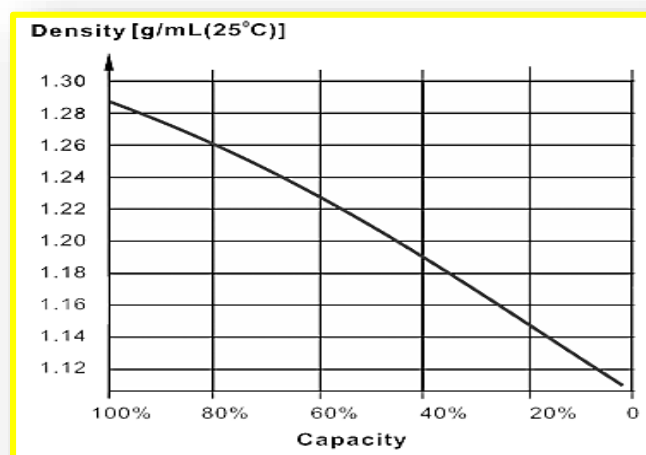

TEMPERATURE vs CAPACITY

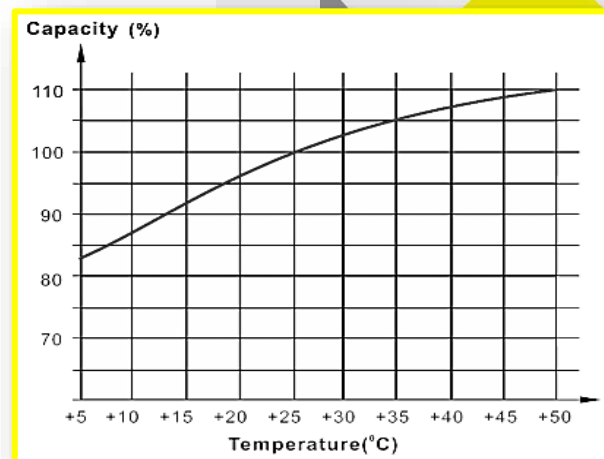

SOLAR Pzs

Deep Cycle PzS Series

DIMENSIONS – TERMINALS - CONNECTORS

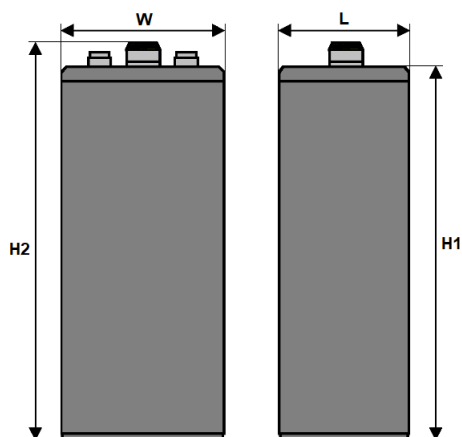

Terminal type: M10 bolt

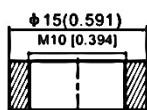

INTERCELL CONNECTORS

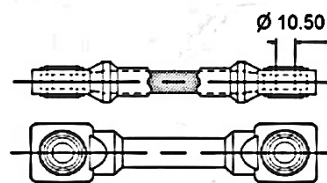

BATTERY BANK LAYOUTS

12V - A

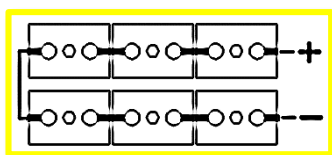

12V - B

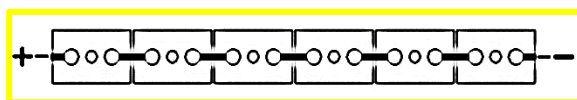

24V - A

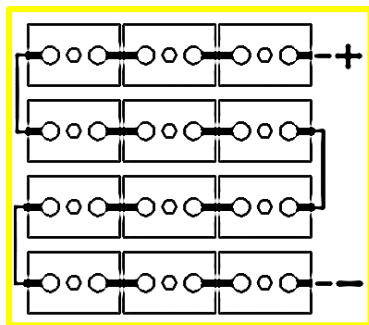

24V - B

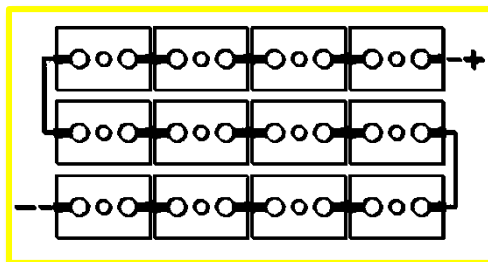

24V - C

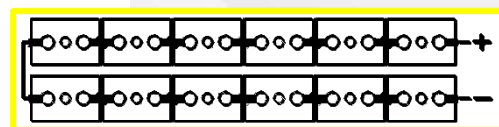

48V - A

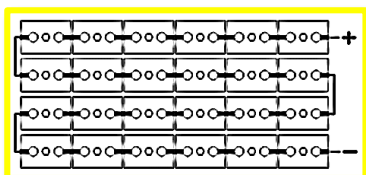

48V - B

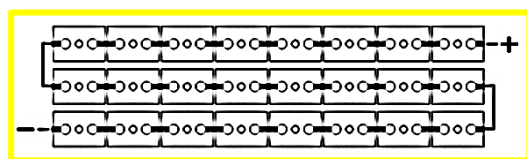

48V - C

